

8100 Series T-Type Filters

FILTER ASSEMBLY PART NUMBER

G 8 1 4F - 3M D S - B1

HOUSING MATERIAL

Code	Material	Pressure (PSI) Operating/Proof/Burst
G	316 SS	6,000/9,000/24,000
P	17-4 SS	10,000/15,000/40,000

FLOW

Code	Flow (GPM /SCFM)
1	1.5/50
12	2.5/175

PORT SIZE

Code	Size	Type
4F	1/4"	NPT
6F	3/8"	NPT

MICRON RATING

	Code	Nominal	Absolute
Cellulose	3C	3	N/A
	10C	10	N/A
Microglass	1M	N/A	1
	3M	N/A	3
	6M	N/A	6
	12M	N/A	12
	25M	N/A	25
Sintered 316SS	1PM	.2	.5
	2PM	.5	1
	3PM	1	2
	4PM	3	5
Wire Mesh	10W	2	10
	18W	5	18
	25W	10	25
	75W	40	75
	100W	75	100
	200W	100	200

* 2.5GPM units offered as stock in 12MD. All other micron options require a MOQ

ACCESSORIES

Code	Accessory	Type
B1	Bowl Drain	1/8" NPT

O-RING TYPE

Code	Description	Temperature (°F)
N	Nitrile (Buna)	-40 to 250
N9	Nitrile 90 Durometer	-40 to 250
V	Viton	-20 to 400
V9	Viton 90 Durometer	-20 to 400
E	EPR	-60 to 300
K	Kalrez	-40 to 550
S	Teflon Encapsulated Viton	-10 to 300
T	Teflon	-320 to 450

- Kalrez and Teflon products will incur additional product cost
- Add the Kalrez o-ring number to the end of the part number (ex: G814F-3MDK-7075-B1)
- Kalrez will incur longer lead times
- Teflon Max operating pressure = 10k psi

COLLAPSE RATING

Code	Material	Material Grade	Rating (PSI)
A	Cellulose	N/A	150
B	Cellulose	N/A	300
C	Microglass	N/A	300
D	Microglass	N/A	3,250
E	Wire Mesh	304 SS	4,500
F	Sintered	316SS	2,000
G	Wire Mesh	316SS	4,500

ADDITIONAL SPECIFICATIONS

1.5 GPM Weight (lbs)	2
2.5 GPM Weight (lbs)	3

REPLACEMENT ELEMENT PART NUMBER

8 1 E - 3M D V

FLOW

MICRON RATING

COLLAPSE RATING

O-RING TYPE

8100 Series T-Type Filters



DIMENSIONS

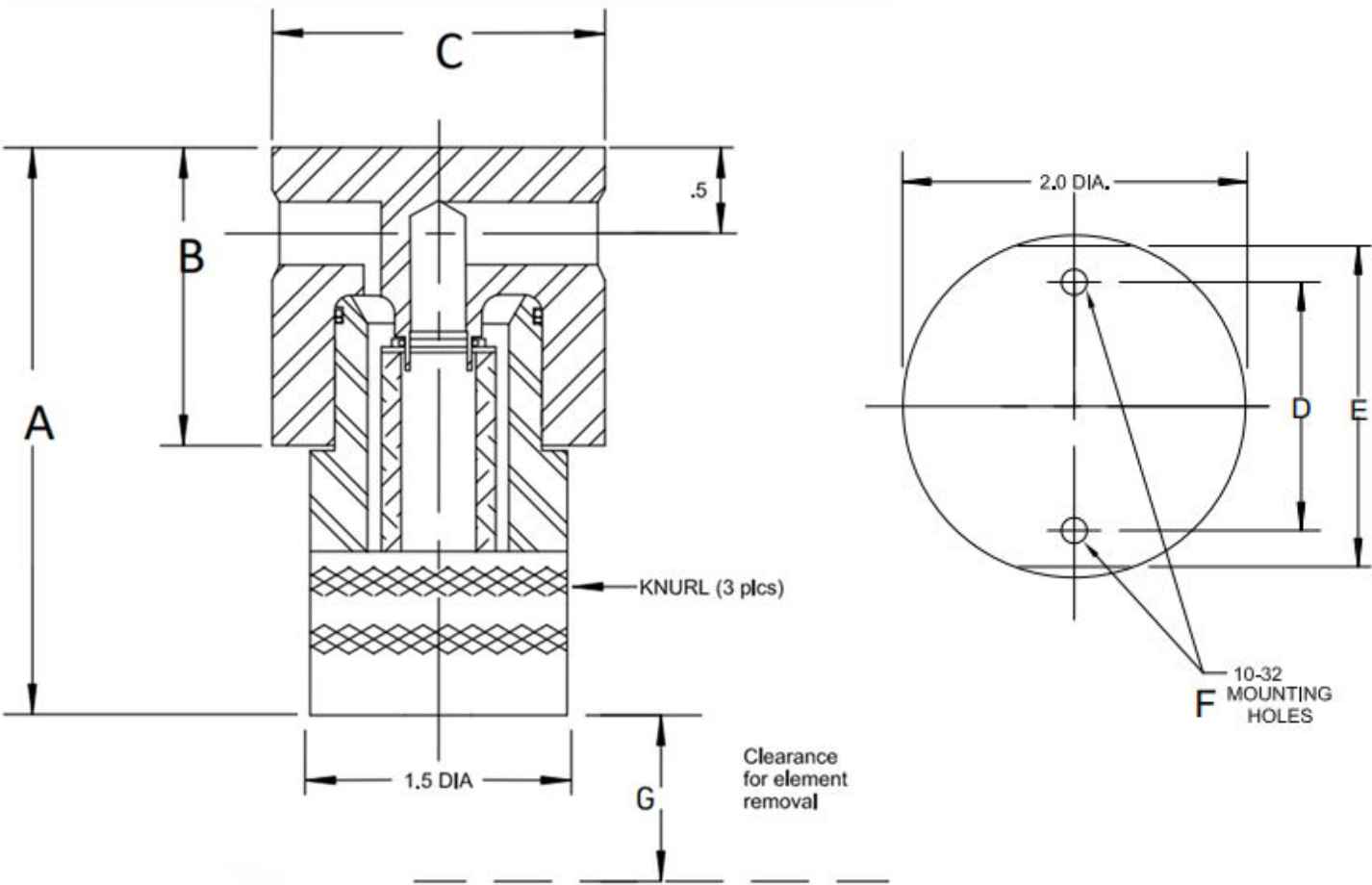

DIMENSIONS			
	G81	P81	G812
A	3.75	3.75	5.5
B	1.84	1.84	1.94
C	2.0	2.0	2.0
D	1.25	1.25	1.25
E	1.8	1.8	1.8
F	10-32	10-32	10-32
G	2.0	2.0	4.0