

# 8700 Series T-Type Filters

## FILTER ASSEMBLY PART NUMBER

**G 879 8F - 12M C N - VE B4**

### HOUSING MATERIAL

Code	Material	Type	Pressure (PSI) Operating/Proof/Burst	Weight (lbs)
A	Aluminum	All	2,000/3,000/8,000	2
G	316 SS	All	6,000/9,000/24,000	6
G1	316 SS	All	10,000/15,000/40,000	17
P	17-4 SS	NPT	10,000/15,000/40,000	17
P	17-4 SS	MP	20,000/30,000/80,000	17
P	17-4 SS	HP	30,000/45,000/120,000	17

### BOWL DRAIN PORT

Code (Optional)	Size	Type	Housing Material	Max Operating Pressure (PSI)
B1	1/8"	NPT	A, G, or G1	10,000
B2	1/4"	NPT	A, G, or G1	10,000
B4	1/4"	SAE	A, G, or G1	10,000
BMP	1/4"	MP	G1 or P	G1 - 10,000 P - 20,000
BHP	1/4"	HP	P	30,000

### PORT SIZE / TYPE / FLOW / OPERATING PRESSURE

Code	Size	Type	Element #	GPM	Housing Options
2F	1/8"	NPT	232	7.5	A*,G*,G1*,P*
4F	1/4"	NPT	232	7.5	A*,G*,G1*,P*
6F	3/8"	NPT	232	7.5	A*,G,G1*,P*
8F	1/2"	NPT	232	7.5	A,G,G1,P
4S	1/4"	SAE	232	7.5	A*,G*,G1*
8S	1/2"	SAE	232	7.5	A*,G,G1*
1	1/4"	MP	232	7.5	G1,P
2	3/8"	MP	232	7.5	G1*,P*
3	9/16"	MP	232	7.5	G1,P
1HP	1/4"	HP	232	7.5	P
2HP	3/8"	HP	232	7.5	P
3HP	9/16"	HP	232	7.5	P*

### ACCESSORY OPTIONS

Code (Optional)	Type	Size / Type	Allowable Accessory Combinations	
V	Visual	N/A	V	E
E	Electrical	N/A	D1 or D2 or D4	VE
B	50psi Bypass	N/A	B or B# [ex: B100]	V(D1/D2/DMP) [ex: VD1]
B#	Custom Bypass (ex: B75 @75psi) Max: 100 PSI	N/A	VB or VB# [ex: VB]	E(D1/D2/DMP) [ex: ED2]
D1	Dp Port	1/8" NPT		
D2	Dp Port	1/4" NPT		
DMP	Dp Port	1/4" MP		EB or EB# [ex: EB]

### MICRON RATING

	Code	Nominal	Absolute
Cellulose (Only A or B Collapse)	3C	3	N/A
	10C	10	N/A
Microglass (Only C or D Collapse)	1M	N/A	1
	3M	N/A	3
	6M	N/A	6
	12M	N/A	12
	25M	N/A	25
Sintered 304SS or 316SS * I/RO (Only F Collapse)	1PM	.2	.5
	2PM	.5	1
	3PM	1	2
	4PM	3	5
	10W	2	10
	18W	5	18
	25W	10	25
Wire Mesh 304SS or 316SS (Only E or G Collapse)	75W	40	75
	100W	75	100
	150W	100	150

\*Non-Standard Port Size per material construction, set up charge incurred if ordering less than 5 for 303, 316, or 17-4 and less than 10 for aluminum

### COLLAPSE RATING

Code	Material	Material Grade	Rating (PSI)
A	Cellulose	N/A	150
B	Cellulose	N/A	300
C	Microglass	N/A	300
D	Microglass	N/A	3,250
E	Wire Mesh	304 SS	4,500
F	Sintered	316SS	2,000
G	Wire Mesh	316SS	4,500

### O-RING TYPE

Code	Description	Temperature (°F)
N	Nitrile (Buna)	-40 to 250
N9	Nitrile 90 Durometer	-40 to 250
V	Viton	-20 to 400
V9	Viton 90 Durometer	-20 to 400
E	EPR	-60 to 300
K	Kalrez	-40 to 550
S	Teflon Encapsulated Viton	-10 to 300
T	Teflon	-320 to 450

- Kalrez, and Teflon products will incur additional product cost
- Add the Kalrez o-ring number to the end of the part number (ex: G8612-K-707512MC-VDCB4)
- Kalrez will incur longer lead times
- Teflon Max operating pressure = 10k psi

### REPLACEMENT ELEMENT PART NUMBER

**232 - 18W E N**

### ELEMENT #

### MICRON RATING

### COLLAPSE RATING

### O-RING TYPE

### ADDITIONAL SPECIFICATIONS

- Omit code is optional accessories are not to be included
- A maximum of up to 2 visual, electrical, Dp and Bypass accessory ports allowed. (See ACCESSORY OPTIONS table)
- Bypass, visual, and electrical indicators tested to 60,000PSI

# 8700 Series T-Type Filters



## DIMENSIONS

### A8700 / G8700

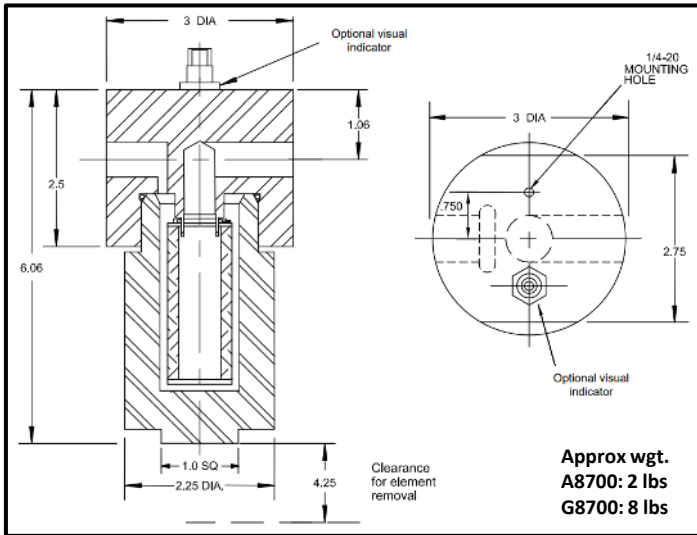

### G1 / P

